

CANDIDATE
NAME

CENTRE
NUMBER

--	--	--	--	--	--

CANDIDATE
NUMBER

--	--	--	--



PHYSICS

Paper 3 Practical Test

5054/32

October/November 2015

2 hours

Candidates answer on the Question Paper.

Additional Materials: As listed in the Confidential Instructions.

READ THESE INSTRUCTIONS FIRST

Write your Centre number, candidate number and name on all the work you hand in.

Write in dark blue or black pen.

You may use an HB pencil for any diagrams or graphs.

Do not use staples, paper clips, glue or correction fluid.

DO NOT WRITE IN ANY BARCODES.

Answer **all** questions.

For each of the questions in Section A, you will be allowed to work with the apparatus for a maximum of 20 minutes. For the question in Section B, you will be allowed to work with the apparatus for a maximum of 1 hour.

You are expected to record all your observations as soon as these observations are made.

An account of the method of carrying out the experiments is **not** required.

Electronic calculators may be used.

You may lose marks if you do not show your working or if you do not use appropriate units.

At the end of the examination, fasten all your work securely together.

The number of marks is given in brackets [] at the end of each question or part question.

For Examiner's Use	
1	
2	
3	
4	
Total	

This document consists of **11** printed pages and **1** blank page.

Section A

Answer **all** the questions in this section.

1 *In this experiment, you will calculate the density of the material used to make some slotted masses.*

You are provided with

- five 100 g slotted masses,
- an empty 250 cm³ beaker,
- a supply of water,
- a 100 cm³ measuring cylinder,
- tweezers or tongs.

(a) (i) Record the total mass M of the five slotted masses.

$M =$

(ii) Place the five 100g slotted masses into the beaker. Pour water from the supply into the beaker until the masses are completely immersed and the water level is at the 250 cm³ mark on the beaker. Carefully remove the masses using the tweezers or tongs without removing any water. Using the measuring cylinder, determine the volume V of water in the beaker.

$V =$

[1]

(iii) Explain the method that you used to determine V .

.....
.....
.....[1]

(iv) Explain two precautions that you took to determine an accurate value for V .

1.
.....
.....
2.
.....
.....

[2]

(b) (i) Calculate the total volume V_S of the five slotted masses.

$$V_S = \dots\dots\dots$$

(ii) Calculate the density ρ of the material used to make the slotted masses using

$$\rho = \frac{M}{V_S}.$$

$$\rho = \dots\dots\dots [1]$$

[Total: 5]

2 In this experiment, you will investigate light reflected from a plane mirror.

You have been provided with

- a plane mirror in a holder,
- an illuminated slit,
- a protractor.

(a) Fig. 2.2 is on the next page.

- On Fig. 2.2, draw a line from point A at an angle of 30° to the line AB. This line should be at least 10 cm long. The end of the line should be labelled X, as shown in Fig. 2.1.
- On Fig. 2.2, draw a line L that is perpendicular to the line AB and is a distance of 3.0 cm from A, as shown in Fig. 2.1.

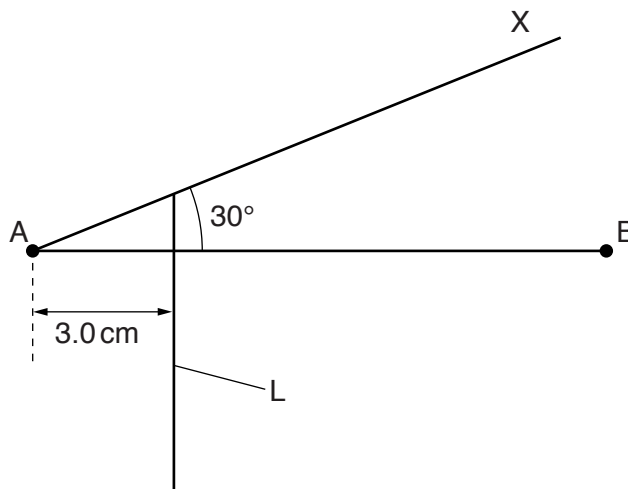

Fig. 2.1 (not to scale)

[1]

- Place the front surface of the mirror along the line AX on Fig. 2.2 with the reflective surface facing towards the bottom of the page. Position the illuminated slit so that a ray of light passes along the line L towards the mirror.
 - Mark two points on the reflected ray. Choose the points so that the reflected ray can be drawn as accurately as possible. Label the points P_1 and P_2 .
- [1]
- Remove the mirror. Draw a line through P_1 and P_2 that extends to the left of AX. Label this line R_1 .
 - On Fig. 2.2, draw a line through A, above AB, at an angle of 60° to the line AB. Place the front of the mirror along this new line with the reflective surface towards the bottom of the page. Again position the light source and slit so that a ray of light passes along line L towards the mirror.

- (iii) On Fig. 2.2, mark and label two points on the ray, reflected from the mirror in its new position. Label these points P_3 and P_4 . Remove the mirror.
- (iv) Draw a line through P_3 and P_4 that meets the line R_1 . Label this line R_2 .
- (v) Measure the angle θ between the lines R_1 and R_2 .

$\theta = \dots\dots\dots$ [3]

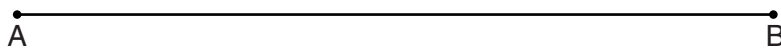

Fig. 2.2

[Total: 5]

3 In this experiment, you will investigate the equilibrium of a half-metre rule.

You have been provided with

- a half-metre rule with a small hook at the 50.0 cm end,
- a card on which the mass of the half-metre rule is written,
- a 10 g mass hanger with nine 10 g masses,
- a thin rod to act as a pivot,
- a length of string with a loop at each end,
- a pulley,
- stands, bosses and clamps to support the rod and the pulley,
- a metre rule,
- a set square,
- protractor.

(a) The Supervisor has set up the apparatus as shown in Fig. 3.1.

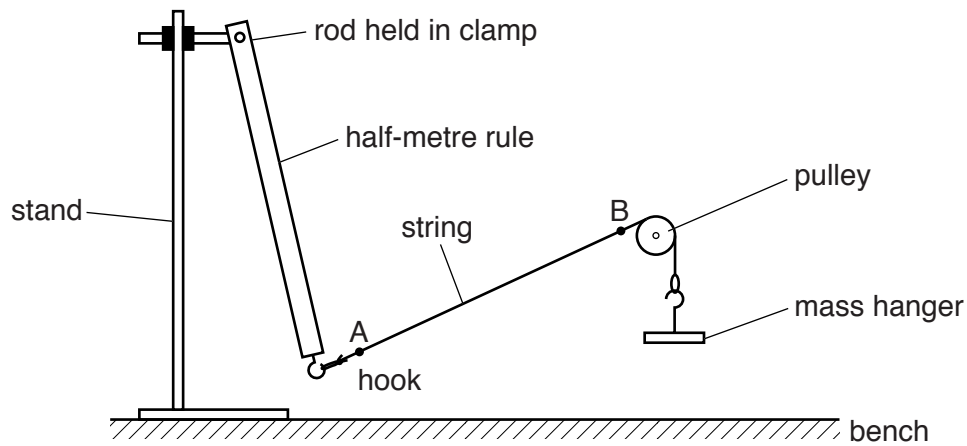

Fig. 3.1

(i) **Initially, do not change the height of the rod held in the clamp or the height of the pulley.**

Add a 10 g mass to the mass hanger and observe that the end of the half-metre rule with the hook rises.

Continue to add 10 g masses until the section AB of the string is as close to horizontal as possible.

If the bottom of the mass hanger reaches the bench before AB is horizontal, increase the separation of the stands holding the rod and the pulley.

Record the total mass m of the mass hanger and the added masses. Also record the mass M of the half-metre rule that is written on the card.

$m =$

$M =$

(ii) Calculate $\frac{m}{M}$.

$$\frac{m}{M} = \dots\dots\dots [1]$$

(iii) The section of the string labelled AB may not be exactly horizontal. If it is not exactly horizontal, make small adjustments to the height of the rod until AB is horizontal. This is shown in Fig. 3.2.

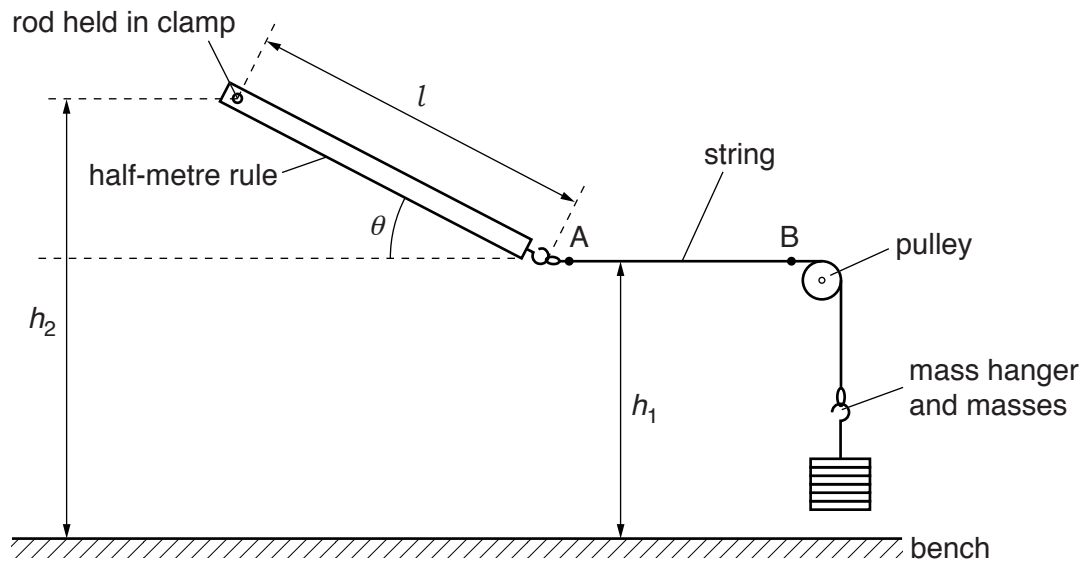

Fig. 3.2

Explain how you checked that the string AB was horizontal. You may add to Fig. 3.2 if you wish.

.....

.....

.....

[1]

(b) (i) Measure and record

1. the height h_1 of the string AB above the bench,

$$h_1 = \dots\dots\dots$$

2. the height h_2 of the centre of the rod above the bench,

$$h_2 = \dots\dots\dots$$

3. the distance l from the centre of the rod to the point where the loop of string meets the hook, as shown in Fig. 3.2.

$$l = \dots\dots\dots$$

[1]

- (ii)** The ratio R of the height difference ($h_2 - h_1$) to the length l gives an indication of the angle θ that the rule makes with the horizontal.

1. Calculate the value of R using $R = \frac{(h_2 - h_1)}{l}$.

$$R = \dots\dots\dots$$

2. Measure the angle θ as shown in Fig. 3.2.

$$\theta = \dots\dots\dots$$

[2]

[Total: 5]

Section B

4 In this experiment, you will investigate a potential divider circuit.

You have been provided with an incomplete circuit consisting of

- a power supply,
- a switch,
- an unknown resistor X ,
- connecting leads.

Three points in the circuit have been labelled A, B, and C. Fig. 4.1 shows the arrangement of the components in the incomplete circuit.

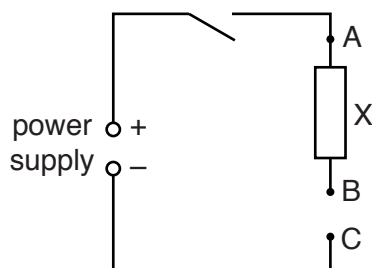

Fig. 4.1

You have also been provided with

- a voltmeter,
- additional connecting leads,
- three resistors labelled with the values of their resistance.

(a) Connect one of the $1.0\text{ k}\Omega$ resistors between points B and C.

- (i) Connect the voltmeter between points A and C. Close the switch and record the reading V_0 on the voltmeter. If you are unable to connect the voltmeter into the circuit, ask the Supervisor for help.

$$V_0 = \dots\dots\dots [1]$$

- (ii) Open the switch and disconnect the voltmeter. Reconnect the voltmeter between points B and C. Close the switch and record the reading V on the voltmeter between B and C. Open the switch.

$$V = \dots\dots\dots [1]$$

(b) (i) Disconnect the 1.0kΩ resistor from between B and C. Connect the 2.7kΩ resistor in its place. Close the switch and record, in the table below, the potential difference V between B and C and the value of the resistance R , in kΩ, between B and C. Include columns for $\frac{1}{V}$ and $\frac{1}{R}$ in your table.

(ii) Open the switch and disconnect the 2.7kΩ resistor from between B and C. Connect the known resistors in series combinations between B and C to give three different values of resistance. Calculate the total resistance R of each combination of resistors and measure the corresponding V . Record your results in the table below.

For two resistors in series $R_{\text{total}} = R_1 + R_2$.

(iii) Open the switch and disconnect the resistors from between B and C. Connect a 1.0kΩ resistor and the 2.7kΩ resistor in parallel between points B and C. Calculate the total resistance of this parallel combination. Close the switch and measure V . Record your results in the table.

For two resistors in parallel $\frac{1}{R_{\text{total}}} = \frac{1}{R_1} + \frac{1}{R_2}$.

(iv) Copy your results from **(a)(ii)** into your table. Calculate the values of $\frac{1}{V}$ and $\frac{1}{R}$ for all your results and complete the table.

[6]

(c) Using the grid opposite, plot a graph of $\frac{1}{V}$ on the y -axis against $\frac{1}{R}$ on the x -axis. Draw a straight line of best fit. [4]

(d) (i) Determine the gradient G of the line of best fit.

$G = \dots\dots\dots$

(ii) Calculate $V_0 G$.

$V_0 G = \dots\dots\dots$

[3]

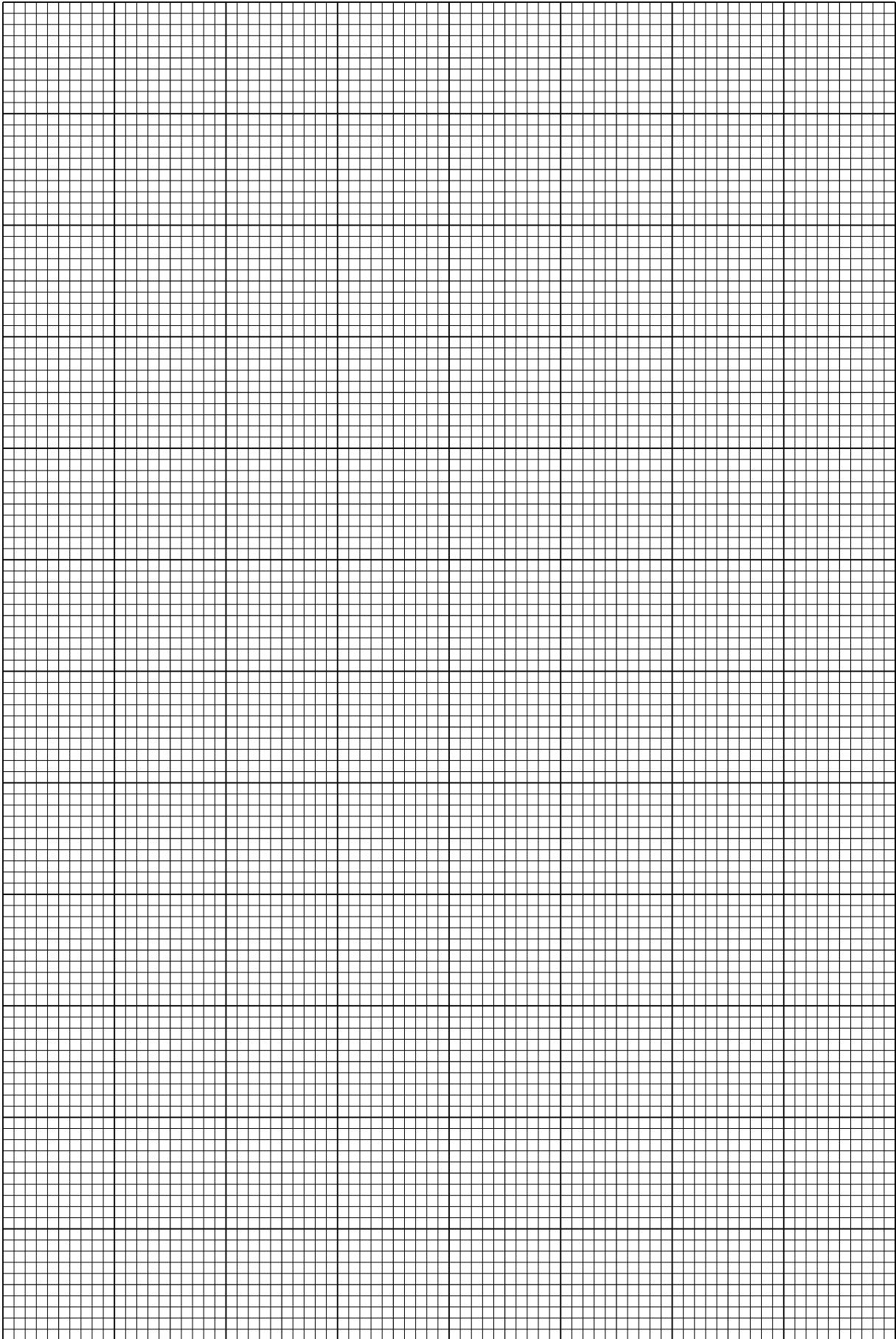

[Total: 15]

BLANK PAGE

Permission to reproduce items where third-party owned material protected by copyright is included has been sought and cleared where possible. Every reasonable effort has been made by the publisher (UCLES) to trace copyright holders, but if any items requiring clearance have unwittingly been included, the publisher will be pleased to make amends at the earliest possible opportunity.

To avoid the issue of disclosure of answer-related information to candidates, all copyright acknowledgements are reproduced online in the Cambridge International Examinations Copyright Acknowledgements Booklet. This is produced for each series of examinations and is freely available to download at www.cie.org.uk after the live examination series.

Cambridge International Examinations is part of the Cambridge Assessment Group. Cambridge Assessment is the brand name of University of Cambridge Local Examinations Syndicate (UCLES), which is itself a department of the University of Cambridge.